

# 7SG164 Ohmega 400 Series

Distance Protection Relays

## Document Release History

This document is issue 2010/02. The list of revisions up to and including this issue is:  
Pre release

2010/02	Document reformat due to rebrand

The copyright and other intellectual property rights in this document, and in any model or article produced from it (and including any registered or unregistered design rights) are the property of Siemens Protection Devices Limited. No part of this document shall be reproduced or modified or stored in another form, in any data retrieval system, without the permission of Siemens Protection Devices Limited, nor shall any model or article be reproduced from this document unless Siemens Protection Devices Limited consent.

While the information and guidance given in this document is believed to be correct, no liability shall be accepted for any loss or damage caused by any error or omission, whether such error or omission is the result of negligence or any other cause. Any and all such liability is disclaimed.

## Contents

1	General .....	3
2	Protection Functions .....	3
3	Output Contacts .....	3
4	Status Inputs .....	3
5	Multiple Setting Groups.....	4
6	Instrumentation and Metering .....	4
6.1	Metering .....	4
6.2	Secondary Values .....	4
6.3	Primary Values.....	4
6.4	Phase Sequence Currents and Voltages .....	4
6.5	Watts .....	4
6.6	VARs .....	4
6.7	Power Factor.....	4
6.8	Load Direction .....	4
7	Data Storage.....	5
7.1	Fault Records.....	5
7.2	Waveform Records .....	5
7.3	Event Records .....	5
8	Communications .....	6
9	Self Monitoring .....	7
10	Password Feature .....	7
11	User Interface .....	7
11.1	General Arrangement.....	7
11.2	Liquid Crystal Display.....	7
11.3	LED Indications.....	8
11.4	Keypad.....	8
12	Settings and Displays.....	8
13	Relay Hardware .....	10
13.1	Internal Construction .....	11
13.2	Front Cover .....	11
13.3	Terminal Blocks .....	11

## 1 General

The relays provide high speed Distance protection and have independent measuring elements for each fault condition and zone of operation. This gives a true full scheme operation. The impedance measurement is a continuous process therefore under impedance starting elements are not required. The relays can include a complete range of feeder protection features supplemented by control, metering, data storage and fibre optic data communication capabilities.

Supervisory components and self-monitoring features give a high confidence of full serviceability. A menu-based interface facilitates user friendly access to relay settings, meters and stored fault data.

The relay can be easily incorporated into substation control and automation systems.

## 2 Protection Functions

Table 1 illustrates the standard functions and Table 2 shows the standard schemes available in all relay models;

Mho Characteristics	High Set Overcurrent
3 Zone	A.C. Line Check (SOTF)
Residual Compensation	D.C. Line Check (SOTF)
3 Pole Tripping	V.T. Supervision
Power Swing Blocking	Voltage Memory

**Table 1 – Standard Protection Functions**

Time Stepped Distance	Blocked Overreach
Permissive Underreach	Permissive Overreach

**Table 2 – Standard Schemes**

In addition to these standard features, different model numbers are available which have extended functionality. These extended features are detailed in Section 12 of this manual.

## 3 Output Contacts

The basic relay model provides 5 output relays, three of which energise changeover contacts, the remaining two energise normally open contacts. The number of output contacts can be increased by groups of 8, to give a maximum of 29 output contacts.

Outputs are user programmable to operate from any or all of the protection functions. In addition they can be programmed to generate outputs for alarm conditions or operate on the energisation of a status input. The relay "Protection Healthy" output is energised whenever the relay is powered-up and working correctly. If the self monitoring feature of the relay detects a hardware fault, or the relay power supply is lost, this contact will drop off.

In their normal mode of operation, output contacts remain energised for at least 100ms, or for the duration of fault. Alternatively, outputs can be programmed to operate as latching contacts if required. Latched output relays can be reset either by pressing the TEST/RESET button, by sending an appropriate data communications command or electrically via a status input.

## 4 Status Inputs

3 plant status inputs are provided in the basic relay, this can be increased in groups of 8, using additional modules to give a maximum of 27 inputs. The inputs can be mapped to dedicated functions within the relay or can be mapped to functional logic blocks or to user defined logic. The inputs can be configured to be high speed signal channels or have a time delayed pickup or drop off function.

## 5 Multiple Setting Groups

The relays provides up to eight alternative settings groups, making it possible to edit one group while the relay protection algorithms operate using another 'active' group. The relay can be switched from one group of settings to another to suit alterations in the power system configuration. The process of changing the settings takes place changed sequentially, and may take up to 2s to update all the settings, during which time the relay remains operative.

A change of group can be achieved either locally at the relay fascia, remotely via a communications interface command or automatically by the energising of a status input. In the case of the last method, the 'Status Configuration'/'Settings Group Select' setting is used to configure any one (or more) of the status inputs to select a settings group. The selected group is then made active if the status input is energised and remains active for as long as the input remains energised. When the input is de-energised the relay returns to the original settings group.

All Settings are stored in non-volatile memory.

## 6 Instrumentation And Metering

### 6.1 Metering

The metering features provide continuous data accessed either from the relay fascia in "**Instruments Display Mode**" or via the data communications interface. While in the display mode pressing the  $\Downarrow$  key accesses the following metering data:

### 6.2 Secondary Values

RMS values for the secondary  $I_A$ ,  $I_B$ ,  $I_C$ ,  $V_A$ ,  $V_B$ ,  $V_C$  values measured by the relay.

### 6.3 Primary Values

RMS values for the primary  $I_A$ ,  $I_B$ ,  $I_C$ ,  $V_A$ ,  $V_B$ ,  $V_C$  values on the system.

### 6.4 Phase Sequence Currents and Voltages

RMS value for the secondary phase sequence quantities measured by the relay. Positive, negative and zero sequence current and voltage are all measured.

### 6.5 Watts

Three phase exported primary power.

### 6.6 VARs

Three phase exported primary VARs.

### 6.7 Power Factor

Cosine of  $\phi$  measured on phase A.

### 6.8 Load Direction

Forward, Reverse on each phase.

Indications showing the condition of the status input signals and the output contacts are available. Where the display indicates a **I** then that position is shown to be active.

The time and date is also displayed.

Where appropriate, additional meter displays are available depending upon the functions supplied with the relay. These will be described in the relevant sections.

## 7 Data Storage

Data records are available in three forms, namely fault records, waveform records and event records. All records are stamped with time and date. The relay incorporates a real time clock feature which keeps time even when the relay is de-energised.

Time and date can be set either via the relay fascia using appropriate commands in the System Configuration Menu, or via the communications interface. In the latter case, relays in a communications network can be synchronised by a global command. Alternatively, time can be synchronised via the IRIG B-12x interface in the relay.

### 7.1 Fault Records

When issuing a trip output under fault conditions, the relay illuminates the relevant LED(s) and, stores a fault record.

This fault record contains the date and time of the occurrence, the active setting group, the flags raised and the distance to fault (if fault location is enabled).

The fault record is viewed in the '**Fault Data Display Mode**' of the menu display system and can be viewed again at a later date. Records are stored for up to 10 faults, the older records being viewed by pressing the  $\downarrow$  button. The displays are numbered from 1 to 10 with fault 1 indicating the most recent record. When each record is viewed the LED's which were indicating at the time of the fault are re-displayed.

The relay triggers the fault recorder (and waveform storage) when the internal logic detects a fault trip condition.

Fault records are stored in capacitor backed memory.

### 7.2 Waveform Records

The waveform record feature stores analogue and digital information for all current inputs, voltage inputs, status inputs and output relays. Waveform storage is triggered by operation of any internal trip function.

In addition, the waveform records can be triggered remotely via a status input or via the serial communications interface.

Waveforms are stored in a rolling 'time window'. The memory is configured for a default of 10 x 1s records but can be set to 5 x 2s, 2 x 5s or 1 x 10s. The pre-trigger can be set in 10% steps over the record length.

Any new record over-writes the oldest when the data memory is full. All records are time and date stamped.

Waveform records are stored in RAM with a capacitor providing back-up during breaks in auxiliary supply.

The waveform records can only be examined once they have been downloaded into a suitable data analysis package such as Reydisp Evolution.

### 7.3 Event Records

The event recorder feature allows the time tagging of any change of state of the relay. Each event is logged with the full date and time and actual event condition every 2.5ms. The following events are logged:-

- Change of setting (though not the actual setting changes). Also indication of which group of settings is active.
- Change of state of Output Relays

- Change of state of Status Inputs
- Change of state of any protection characteristic
- Main Trip

Other events are available depending upon the features included in the relay -they are described with the relevant feature.

The event storage buffer holds at least 500 records. When the event buffer is full, then any new record overwrites the oldest.

Event records are stored in RAM with a capacitor providing back-up during breaks in auxiliary supply.

The event records can only be examined once they have been downloaded into a suitable data analysis package such as Reydisp Evolution or by interrogation of the SCADA system.

## 8 Communications

A front mounted RS232 port and two rear fibre optic communication ports are provided.

Communication is compatible with the IEC60870-5-103 transmission and application standards. The fibre optic interface gives superior EMC performance. A user friendly software package (Reydisp Evolution) is available to allow transfer of the following:

- Relay settings
- Waveform records
- Event records
- Instruments and meters
- Control Functions

Communications operation is described in detail in the Communication Interface Manual

## 9 Self Monitoring

The relay incorporates a number of self-monitoring features. Each of these initiates a reset sequence, which can be used to generate an alarm output. In addition, the Protection Healthy LED gives visual indication.

A watchdog feature monitors the microprocessor while the relay has a self-check feature for the program memory, which is continuously checked for data corruption.

The power supply is continuously supervised. Any failure is detected with sufficient time warning so that the microprocessor can be shut down in a safe and controlled manner.

## 10 Password Feature

The programmable password feature enables the user to enter a 4 character alpha-numeric code. The relay is supplied with the password function disabled. To enable the password feature the user must first enter a password. Verification of this is asked for and then this becomes the valid password.

As soon as the user attempts to change a setting the password is requested before any setting alterations are allowed. Once the password has been validated, the user is said to be "logged on" and any further changes can be made without re-entering the password. If no more changes are made within 1 hour then the user will automatically be "logged out", re-enabling the password feature.

Note that the password validation screen also displays a numerical code. If the password is lost or forgotten, this code can be communicated to Siemens by authorised personnel, and the password can be retrieved.

The relay is supplied with the password set to "**NONE**" which means the feature is de-activated.

To de-activate the password change the password to "**NONE**" the function will now be disabled.

## 11 User Interface

The user interface is designed to provide a user-friendly method of entering settings and retrieving data from the relay. The HMI is shown in 1.

### 11.1 General Arrangement

All relay fascia includes a liquid crystal display, 33 light emitting diodes, 5 push buttons and an RS232 data communications socket.

The LCD has a 20 character by 2 line display which is backlit.

### 11.2 Liquid Crystal Display

The liquid crystal display is used to present settings, instruments and fault data in a textual or graphical format.

The contrast of the display may be changed by pressing TEST/RESET and either the up or down key simultaneously.

The display back lighting is turned off to conserve power if no pushbuttons are pressed for a set time delay (the backlight timer which is set to 5 minutes by default). After a further delay (Default screens timer, default 60 minutes), the display will revert to the defaults screen(s). The relay will then cycle through screens selected in the defaults screen list, changing screens every few seconds (unless the default screens timer setting is set to OFF). The defaults screen list always includes the 'RELAY IDENTIFIER' screen. Additional instruments screens can be added to the defaults screens list by pressing the ENTER key when the required screen is being viewed. A 'D' symbol appears on the screen to show that the screen is now in the list.

## 11.3 LED Indications

The following indications are provided:

Protection Healthy - Green LED.

This LED indicates that DC volts have been applied to the relay and that the relay is operating correctly. If a permanent fault is detected by the internal supervision, then this LED will continuously flash.

Red LED –

These LED's indicate that a trip or protection operation as defined by customer setting has occurred. Such an operation may have been issued by any of the relays functions or by a change of state of a status input - all red LEDs are user programmable and can be assigned to any output function. Any of the red LEDs can be defined as self reset as opposed to the default of latched such that the led will be extinguished when the output stimulus is removed.

Listed below in Table 3 is an example of indications provided by the LEDs. Some of these will not be applicable when the relay is not provided with the relevant associated feature. Note a full list of the LED indications available in the particular model of the relay is provided in Section 4 of this manual.

Zone 1	Carrier Receive 2
Zone 2	DEF Aided Trip
Zone 3	Carrier Receive Guard
Zone 4	Switch onto Fault
Zone 5	VT Fail
Phase "A"	Overcurrent Highset
Phase "B"	Power Swing alarm
Phase "C"	Power Swing trip
Earth	Broken Conductor
Carrier Receive 1	Stub Protection
Aided Trip	Autoreclose in progress
DEF Forward	Autoreclose lockout
DEF Reverse	CB open

**Table 3 – Typical LED Indications**

## 11.4 Keypad

Five push buttons are used to control the functions of the relay by moving around the menu display. They are labelled ↓ ↑ ⇒ **ENTER** and **CANCEL**. Note that the ⇒ button is also labelled **TEST/RESET**.

Only two push buttons are accessible when the front cover is on. These are the ↓ and ⇒ buttons, allowing read access to all displays.

## 12 Settings And Displays

The model specific settings/displays flow diagram is shown in the settings section of this manual, section 4. The diagram below shows the basic structure for demonstration purposes. This diagram shows the three main modes of display, the SETTINGS DISPLAY MODE, the INSTRUMENT DISPLAY MODE and the FAULT DATA DISPLAY MODE.

On relay start up, the user is presented with a default relay identifier. This can be changed (In the SYSTEM CONFIG MENU) to some user-definable identifier or code if the user prefers.

Settings display mode is entered by scrolling down from the relay identifier display. The ⇒ key can then be used to move to the INSTRUMENT and FAULT DATA DISPLAY MODES in turn.

The settings display mode contains all the menus which hold the programmable settings of the relay. It contains a series of sub-menus with typical title displays as follows:



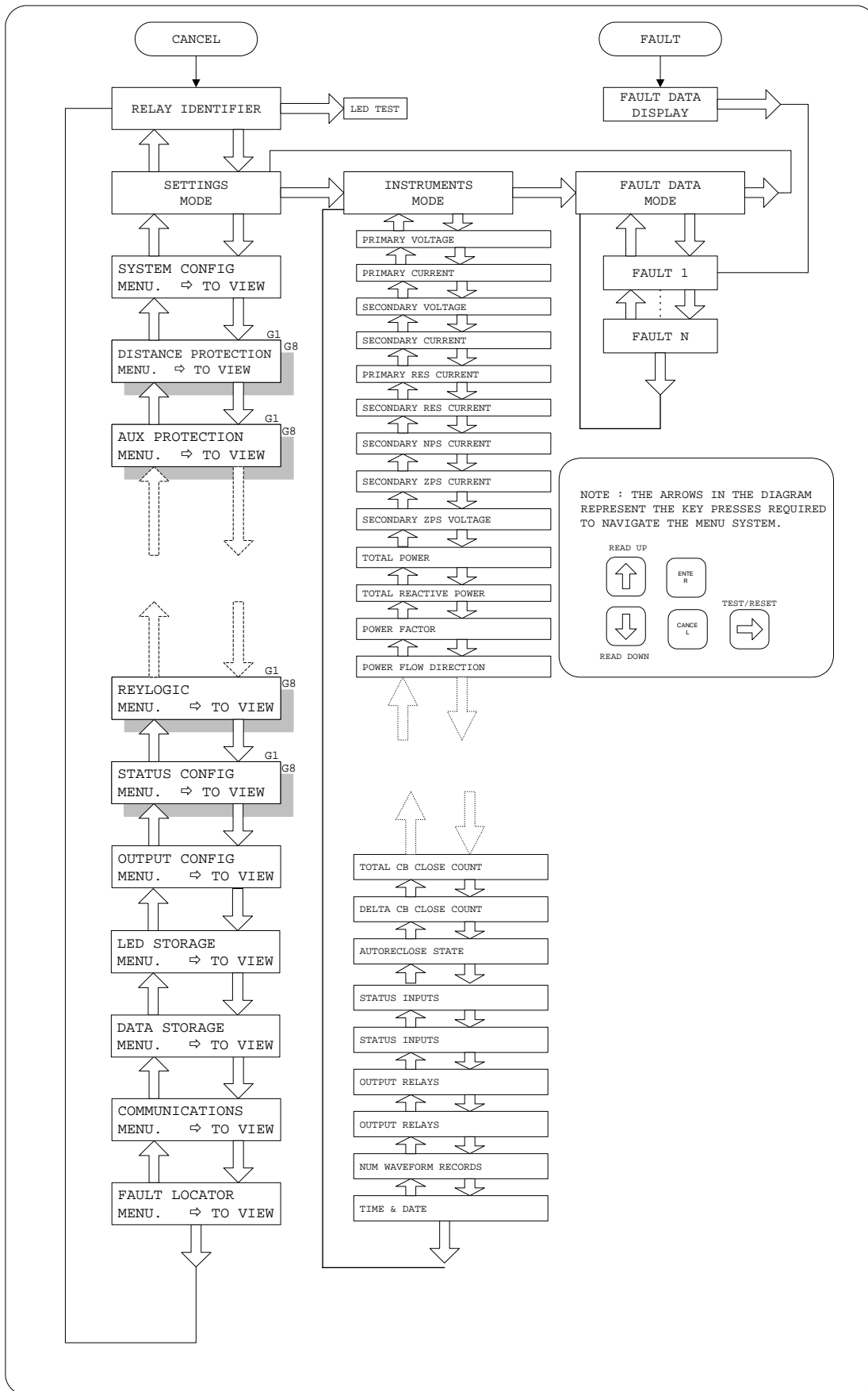

A sub-menu is opened by pressing the ⇨ key when viewing one of the above title screens. The settings within the sub-menu can then be viewed in turn. Leaving a sub-menu, by scrolling either upwards or downwards, causes it to be automatically closed. It must be re-opened in order to view its settings again.

- (1) Pressing ↑ / ↓ scrolls up / down, viewing the screens. All screens can be viewed even if the password is not known - the password only protects the relay against unauthorised changes.
- (2) While viewing an editable screen, **ENTER** allows the user to change the displayed data, indicated by flashing character, as long as the changes are authorised via password verification. Pressing ↑ / ↓ increments / decrements that particular character, while ⇨ moves right along the edit field or fields. If ↑ or ↓ are held pressed while scrolling through a range of numerical settings then the rate of scrolling increases.

**CANCEL** returns the screen to view mode and restores the most recently stored setting.

- (3) If changes are made, pressing **ENTER** alters the values on that screen and **immediately** stores the changes into non-volatile memory. This also returns the screen to view mode and allows ↑ / ↓ to move to the previous / next screen.

There are eight separate 'Settings Groups'. The different settings groups can be viewed or edited independently and indication of which group is presently being viewed is given by the 'G?' character in the top left of the display.

The setting selections, setting ranges and default values can be found at the end of each relevant section in the technical manual.

## 13 Relay Hardware

The range of relays are housed in the Epsilon case - size 16.

The relay hardware is illustrated in 1.

The build consists of up to eight internal hardware modules as well as the fascia module. All relay models are supplied with the following modules:

Module A	Power supply + basic I/O
Module E	Voltage inputs
Module F	Current inputs
Module G	Analogue input processing
Module H	Protection processor and controller

Modules B, C and D are optional giving additional input/output capability.

The fascia PCB includes the human machine interface (HMI), with pushbuttons for entering settings, an LCD for displaying alphanumeric and optionally graphical information and LEDs for indication. A 25 pin RS232 D type connector is located on the front plate to allow local data communications.

Current and voltage input signals are carried from the input modules via the data acquisition bus (DAQ) to the analogue input processor card for processing. The processed inputs are in turn carried to the protection processor/controller module via the expanded I/O bus.

Two remote data communications interfaces - fibre optic - and an IRIG-B connector are located behind module H and connected into the controller card.

A 34 way ribbon cable connects the I/O and fascia modules to the processing and protection processor/controller modules and a 26 way ribbon cable connects the analogue modules to their processor and another 26 way ribbon cable connects the processors together.

## 13.1 Internal Construction

The design for the internal arrangement of each module has been chosen to provide a high level of EMI screening, using multi-layer PCBs with ground planes, RFI suppression components and earthed metal screens.

The case is segregated internally into electrically noisy and quiet areas in order to improve noise immunity and reduce RFI emissions. The only direct connection from the quiet components to the external environment is via the serial communication interfaces. The optical interfaces are immune to radiated or conducted interference.

## 13.2 Front Cover

After the relay has been commissioned, a clear plastic front cover is fitted. This allows the user to see the entire front of the relay, but only allows access to the ↓ and ⇒ buttons, allowing all of the menus discussed previously to be viewed but not changed. The only 'action', which is permitted, is to reset the Fault Data Display, latched output relays and the latched LEDs by using the **TEST/RESET** function of the ⇒ button.

## 13.3 Terminal Blocks

These are of the standard Epsilon design, consisting of six blocks - behind modules A to F - with 28 terminals per block. All inputs and outputs (except for the serial communications interface) are made through these connectors. Where CT's and normally closed output contacts are fitted the terminals are provided with CT shorting contacts to provide system integrity when these modules are removed.

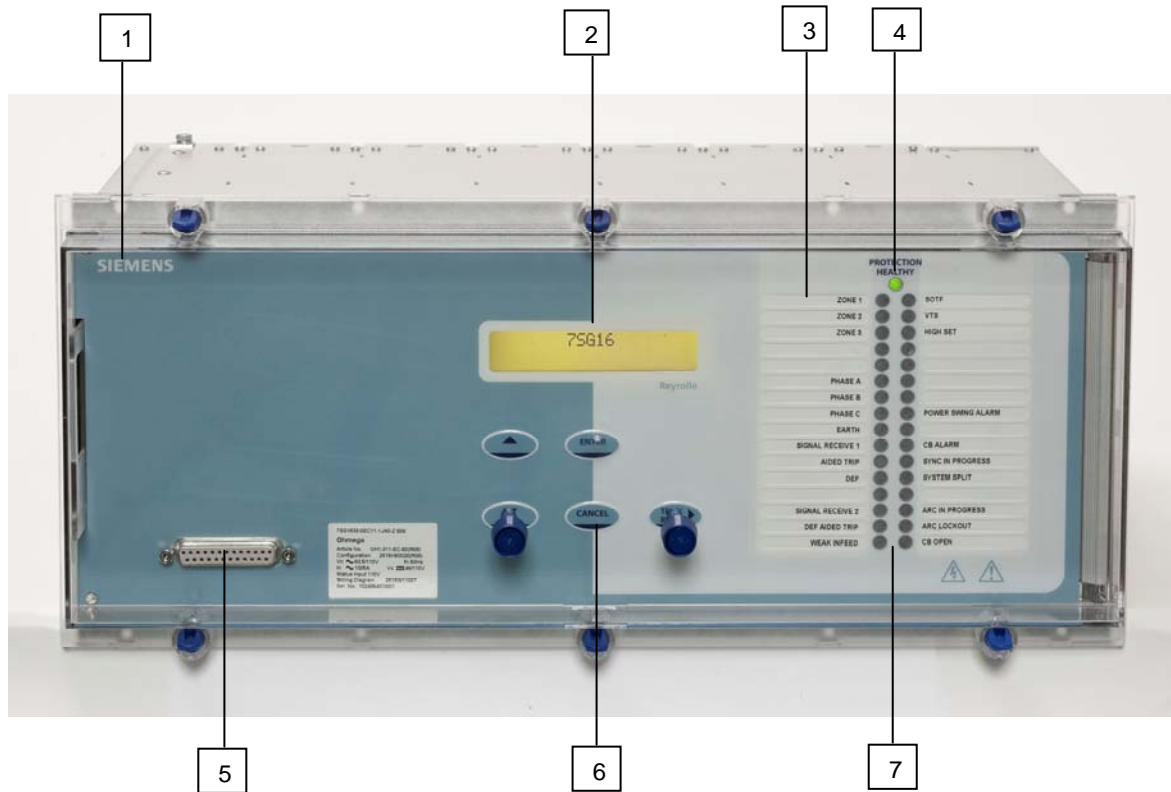

**Figure 1 –Human Machine Interface (HMI)**

### Features

- 1 Relay type
- 2 2 line 20 character back lit L.C. display
- 3 Alarm description
- 4 Protection healthy L.E.D.
- 5 Local RS232 port
- 6 Five button key pad
- 7 32 programmable alarm and trip L.E.D's